



The Maple™ System

5" LED Square Frame & Light Engines

LED Square **Frames**

5" LED Light **Engines**

Introducing The Maple™ System

ELCO Lighting's Maple System is the perfect luminaire for commercial, hospitality and multi-story applications. The system is offered with a plaster frame and four different LED light engines in a variety of lumen outputs and color temperatures. As newer structures are being designed with smaller plenum spaces between floors this product has been engineered to be as shallow as possible to fit almost any above ceiling space while maintaining strong lumen output and light quality.

The Maple™ System

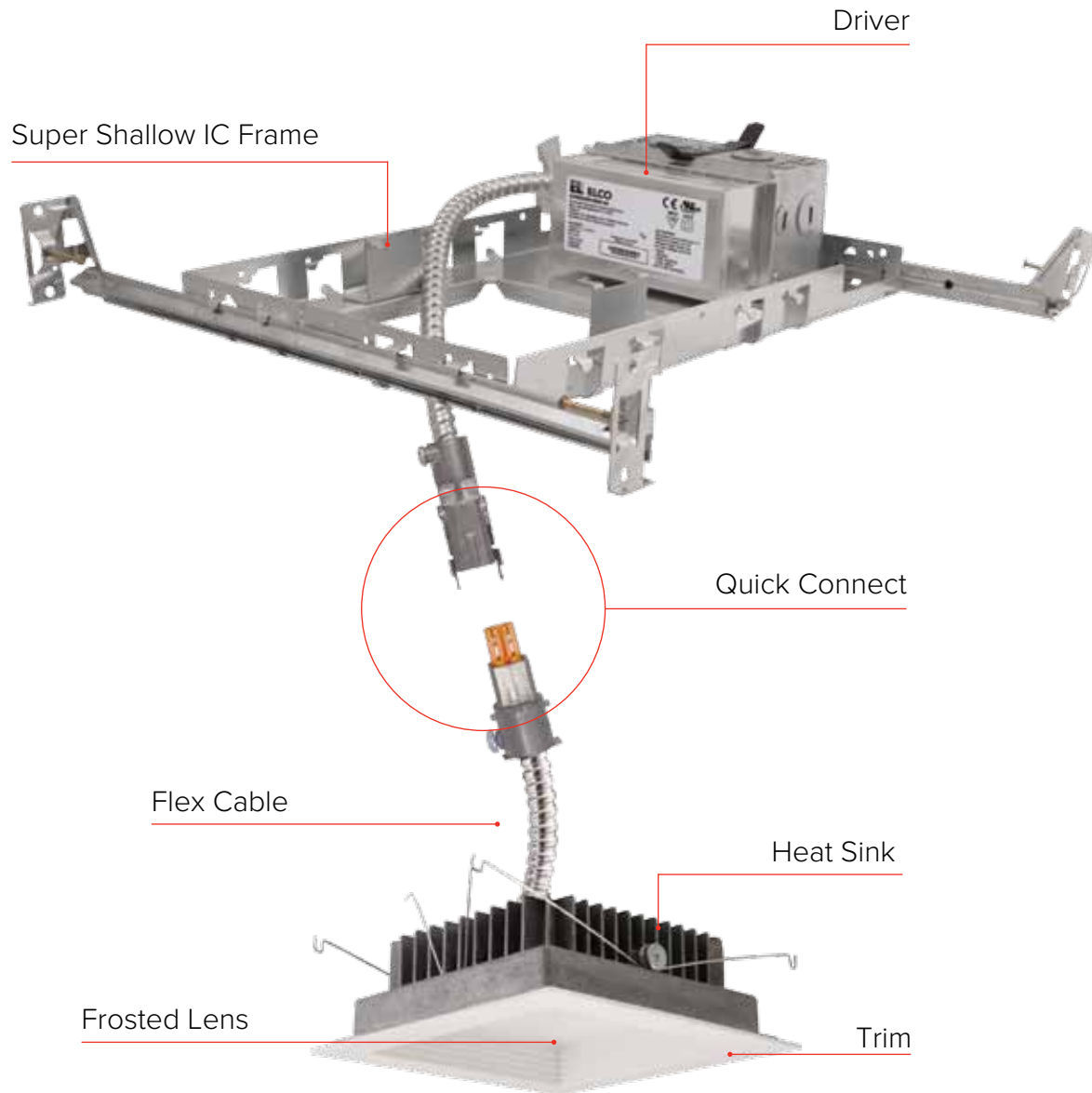

5" Shallow Housing & Light Engine

- Up to 2000 lumens
- 120/277V input with Triac/ELV or 0-10V dimming options
- Downlight and adjustable trims available
- 3000K and 4000K available
- IC Rated without any bulky boxes
- Can be installed in residential woods structures, or commercial buildings drop ceilings

IC Shallow Frame with Driver



With Optional Emergency Battery Backup

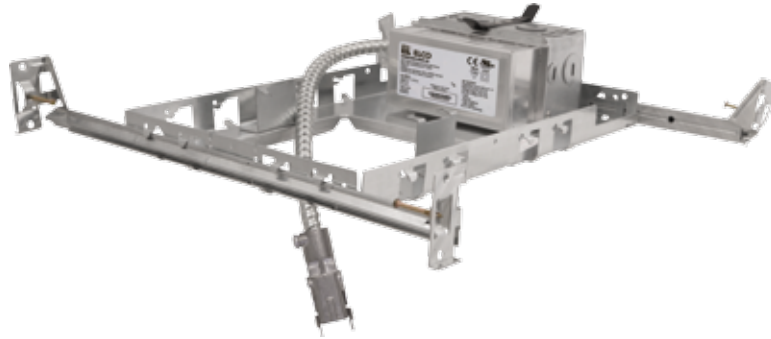

Input Power	16W - 28W
Lumens	1100 - 2000
Voltage	120/277V
Color Temp	3000K - 4000K
Dimmable	Triac/ELV or 0-10V
Wet Loc	UL Listed

Baffle & Reflector Light Engines

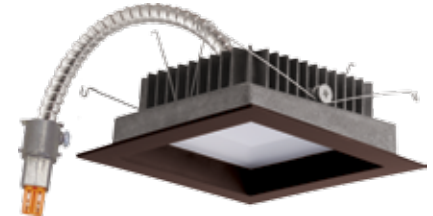

Adjustable Pull-Down