

Fire Enclosure Items!

FIRE BARRIER FOR RECESSED HOUSINGS

Fire Enclosure (FIREENCL)

- Flexible fire enclosure provides fire barrier around recessed fixtures.
- ETL approved for 1 hour fire resistance.
- Water resistant with thermal & sound dampening effect.
- Can be used as vapor barrier for other openings.
- Meets UL 263 and ASTM requirements.
- Easy installation reduce labor cost significantly.
- Mounts quickly with staples, nails or screws with flat washers to the ceiling structure. (2" wide nail flange on all sides).
- Fits both 16" & 24" on-center ceiling constructions.
- Can be installed before or after recessed fixture installation.
- To be used with tape (FIRETAPE) to seal the power feeding point (sold separately).

**1 HOUR
FIRE RATED**

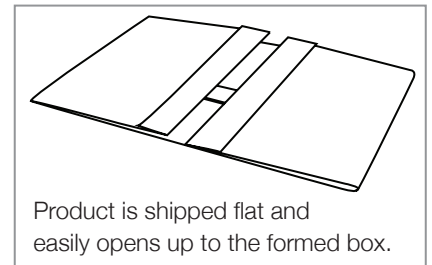
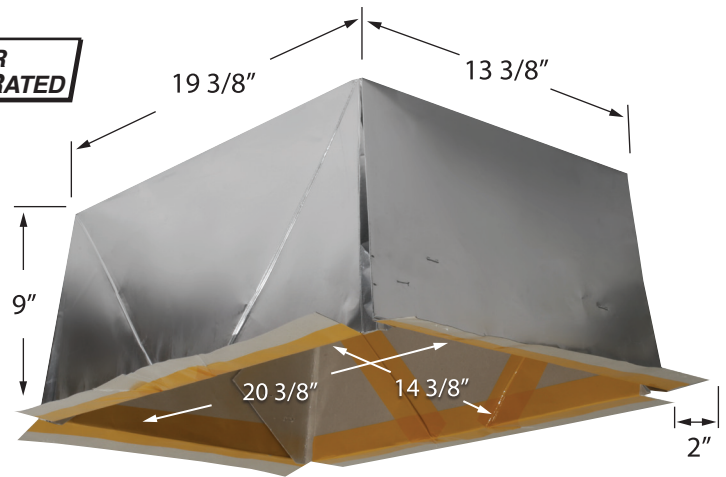

Fire Tape (FIRETAPE)

- Adhesive tape to seal the power feeding point on FIREENCL.
- 3/4"W x 6'6"L



**For large orders
quotes please
contact your sales
representative.**

Fire Cover (FIRECVR)

- UL Listed recessed light enclosure stops flame spread and heat transmission for up to 2 hours.
- UL approved for most major ceiling types, including gypsum, sheetrock, suspended drywall and acoustical tiles.
- Lightweight and flexible.
- Made of heat activated material.
- Provides thermal and acoustical insulating properties.
- Easy to install, requires no assembly or additional sealant.
- For joint/trusses from 2"x10" to 2"x24".

**2 HOUR
FIRE RATED**

