

NEW Teak™ System 2" LED Pull-Downs in Stock!

2" Teak™ Housings & Frames

- Listed for direct contact with insulation
- UL listed - Damp location listed
- JA8 2016-E listed
- Driver included



2" R60 IC New Construction Housing

120V (Triac/ELV)	120/277V (0-10V/Triac/ELV)
E2LAJ08ICA 850 lm	E2LAJ08ICAD 850 lm
E2LAJ11ICA 1100 lm	E2LAJ11ICAD 1100 lm



2" IC New Construction Frame

120V (Triac/ELV)	120/277V (0-10V/Triac/ELV)
E2L08ICA 850 lm	E2L08ICAD 850 lm
E2L11ICA 1100 lm	E2L11ICAD 1100 lm



2" IC Remodel Power Pack

120V (Triac/ELV)	120/277V (0-10V/Triac/ELV)
E2L08RIC 850 lm	E2L08RICD 850 lm
E2L11RIC 1100 lm	E2L11RICD 1100 lm



2" Pull-Down LED Light Engines

- Same module for 850 (8.6W), 1100 lm (10.5W) based on frame
- 80° Adjustability
- Listed for direct contact with insulation, Airtight
- Standard with 38° beam. Field changeable optics for 28° (EP716C) and 60° (EP718C)
- UL listed for damp locations
- JA8 2016-E listed
- Meet ENERGY STAR requirements
- 50,000 hours L70 life-span
- Requires compatible ELCO Housings, Frame or Power Supply

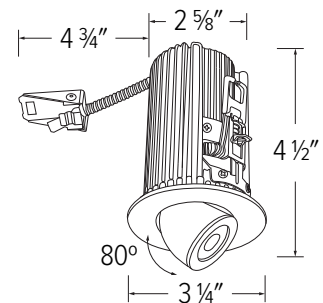

FINISH	2700K	3000K
White	E2L97F27W	E2L97F30W
Black	E2L97F27B	E2L97F30B
Bronze	E2L97F27BZ	E2L97F30BZ

For large orders quotes please contact your Sales Representative

Log on to elcolighting.com for more **2" Teak™ Light Engines!**

Subject to US tariffs. All other standards, terms and conditions apply.
 Please provide your e-mail address to salesadmin@elcolighting.com.
 To unsubscribe e-mail: salesadmin@elcolighting.com

E-mail your order to: orderdesk@elcolighting.com
 Tel: 800.522.2626 • Fax: 800.644.2626

ELCO Lighting
 The Best Choice in Lighting