



**WARNING:**

Risk of electric shock. Before wiring to power supply, turn off electricity at the fuse or circuit breaker box.

**CAUTION:**

For your safety read and understand instructions completely before starting installation. Installation requires knowledge of luminaire's electrical system. If not qualified, DO NOT attempt installation. Contact a qualified electrician if necessary.

**NOTE:** Before beginning the installation, carefully unpack and identify all parts.

**Rated Voltage for EL434CT5XX — 120VAC, 60Hz**  
**Rated Voltage for EL487CT5XX — 100-277VAC, 60Hz**

**GENERAL:** All electrical connections must be in accordance with local and National Electrical Code (N.E.C.) standards. If you are unfamiliar with proper electrical wiring connections obtain the services of a qualified electrician.

Remove the KIT from the box and make sure that no parts are missing by referencing the PARTS illustrations.

THIS RETROFIT ASSEMBLY IS ACCEPTED AS A COMPONENT OF A LED LUMINAIRE WHERE THE SUITABILITY OF THE COMBINATION SHALL BE DETERMINED BY CSA OR CANADIAN AUTHORITIES HAVING JURISDICTION.

THIS DEVICE IS NOT INTENDED FOR USE WITH EMERGENCY EXITS.

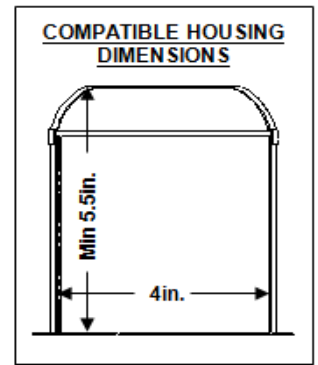
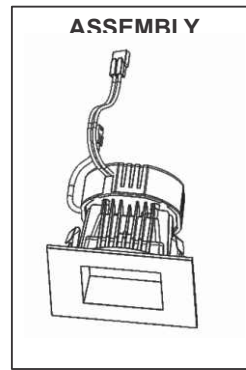

**WARNING- RISK OF FIRE OR ELECTRIC SHOCK**

- LED Insert installation requires knowledge of luminaire's electrical systems. If not qualified, do not attempt installation. Contact a qualified electrician.
- Install this kit only in luminaires that have the construction features and dimensions shown in the photographs and/or drawings and where the input rating of the retrofit kit does not exceed the input rating of the luminaire.
- Do not make or alter any open holes in an enclosure of wiring or electrical components during kit installation.
- To prevent wiring damage or abrasion, do not expose wiring to edges of sheet metal or other sharp objects.
- The inside of the ceiling must be waterproof.

**ASSEMBLY AND INSTALLATION**  
**Dedicated LED Housing**

1. Make sure the power is off before installing or performing maintenance on the fixture.
2. Use the toggle switch to select your desired lamp color temperature, 2700K/3000K/3500K/4000K/5000K. (Fig. 1)
3. For EL487CT5XX, please select the power needed before installation (10W/14W/18W) (Fig. 1). Please skip this step otherwise.
4. Mate the FEMALE ORANGE CONNECTOR of the LED insert onto the MALE ORANGE CONNECTOR of the housing for the supply voltage. If applicable, mate the FEMALE BLACK CONNECTOR of the LED insert onto the MALE BLACK CONNECTOR of the housing for 0-10V control. (Fig. 2).
5. After connecting the wires, carefully install the lamp into the housing (Fig. 3)
6. Installation is complete. Please switch on the power.

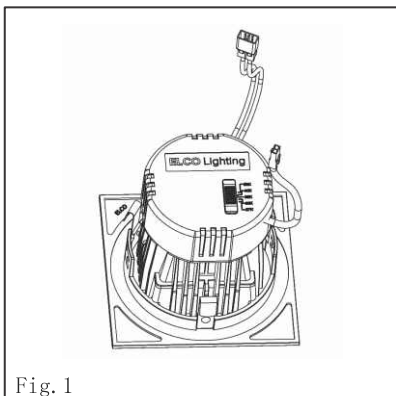

Fig. 1

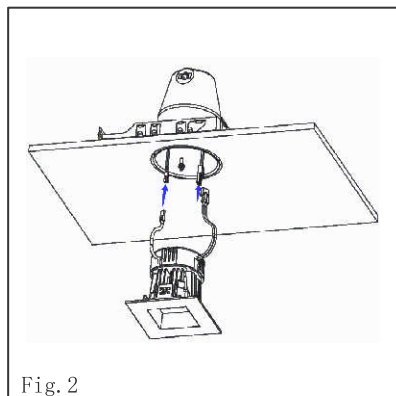

Fig. 2

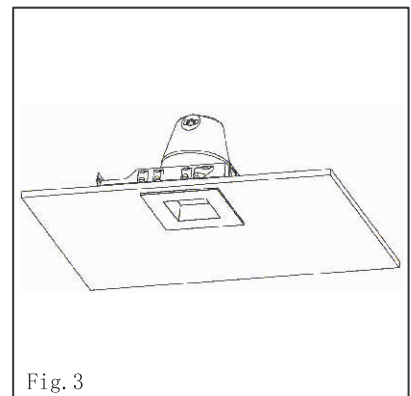

Fig. 3