

Deep Mount Aluminum Channel

the Ambio™ EUD32 is a high-quality aluminum channel designed to add an architectural element to LED strips while protecting them from dust and dirt. Manufactured with a frosted diffuser, that can be slid or popped on, the channel eliminates the dotting caused by LED diodes and allows the eye to simply glide across the smooth, wide distribution of light. And, owing to its superior thermal management the product extends the life of the LED Tape. Easy to install and easy to fit with standard lengths and factory custom cuts available.



Features

- Polycarbonate diffuser
- Silver aluminum finish
- Fits tape lights up to 12mm (1/2") wide
- Includes frosted lens, 2 end caps, 4 mounting clips
- Aluminum Channel is approximately 7'8" long

Technical Details

Construction: Premium grade aluminum channels. Can hold tape up to 12mm (1/2") wide.

Optics: Included frosted lens which eliminates LED pixilation and protects the LED strip. Lens can be popped on or slid onto the profile.

Installation: Can be surface mounted to flat surface. LED tape is placed into channel using 3M tape backing on LED Tape Light. Lens can be either popped or slid onto channel.

Compatible Tape: E15-24, E22-24, E30-24, E44-24, E44-24M, E45-24, EW44-24, EW45-24, E50-24, E60-24, EF26-24, EWP460 and E460

Dimensions

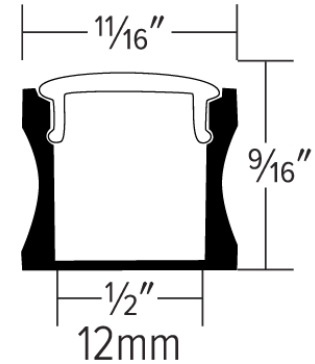

Product Numbers

Item	Description	Finish
EUD32-8	8' Deep Mount LED Aluminum Channel w/lens & connectors	Aluminum
EUD32	Custom Cut Deep Mount LED Aluminum Channel	Aluminum