

# 8" New Construction Incandescent Architectural Housing



## Features

- 8" Incandescent Commercial Downlight Architectural Housing.
- Galvanized Steel construction, commercial frame.
- Single Wall construction.
- Integral Thermal Protector.
- PAR30, PAR38 or A19, Lamp and Hanger Bars not included.
- Trims feature white polycarbonate ring
- UL Listed for damp location.
- Compatible Trims: EL816, EL832, EL833, EL836, EL838, EL852.

## Specifications

<b>Wattage</b>	200W
<b>Voltage</b>	120V
<b>Lamp Type</b>	Medium Base (E26)
<b>Damp Location</b>	Listed

## Dimensions

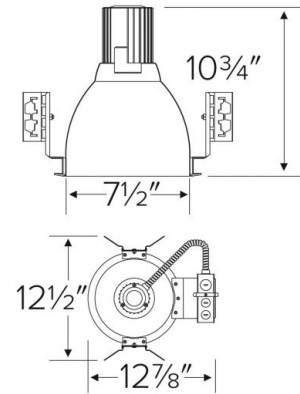

## Product Numbers

Item	Lamp type	Watts	Voltage
ELH8T	Medium Base (E26)	200W	120V