

8" Incandescent IC Square Housing



Features

- Square housing, Type IC, Airtight (with lensed trims).
- Double wall aluminum construction.
- Integral thermal protector.
- Supplied with captive bar hangers for 24" max joist spacing.
- Lamp: 120V 75W MAX A19.
- cUL listed for Damp Location and for Feed Through.

Specifications

Wattage	75W
Voltage	120V
Lamp Type	Medium Base (E26)
Damp Location	Listed

Dimensions

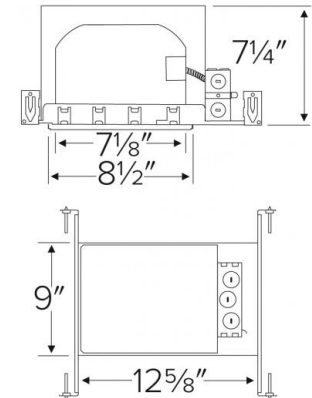

Technical Details

Construction:

- IC rated for direct contact with insulation, for use in IC or non-IC conditions.
- Housing adjusts in frame to accommodate up to 1 1/4" ceiling thickness.
- Airtight housing with lensed trims to restrict airflow in accordance with ASTM E-283 air-tight requirements.
- Aluminum housing for greater heat dissipation. Stamped galvanized steel frame.

Installation: Designed for ceiling plenums where 2x8 joists or taller are used. High strength hanger bars can easily be nailed to joists. Maximum hole cutout is 8 1/2". Suitable for T-grid and drop ceiling applications. See installation sheet for detailed information.

Junction Box: Positioned to accommodate straight conduit runs. Seven 1/2" trade size pryout conduit knockouts, 4 Romex pryouts with strain relief.

Hanger Bars: Pre-installed hanger bars with True Nail facilitate easy installation in regular lumber, engineered lumber, and laminated beams. Integral T-bar slots for easy installation in T-grids. Spans up to 24" and can be repositioned 90°. Score lines allow for tool-free hanger bar size reduction. Integral leveling flange allows for single-person installation while aligning the housing with the joists.

Electrical:

- Input Voltage: 120V AC.
- Thermally protected against improper lamping.

Trims: Compatible with EL10W, EL11W, EL15W, EL88130W.

Lamp: Designed for use with Medium Base (E26) PAR lamps up to 75W.

Listings:

- cUL Listed for Damp Location.
- cUL Listed for Feed Through.
- cUL Listed for Direct Contact with Insulation and Combustible Material.
- Airtight per ASTM E-283.

Warranty: ELCO Lighting warrants products will be free from defects in materials and workmanship for a period of 3 years.

Product Numbers

Item	Lamp type	Watts	Voltage
EL85QICA	Medium Base (E26)	75W	120V

Compatible Products

For use with 8" Square E26 Base Housings

8" Square LED Retrofit Insert



Square LED Insert

CAT NO.	SPECIFICATIONS
EL88130W	19W, 1460 lm, 3000K, 120/277V, Triac/ELV
EL88140W	19W, 1520 lm, 4000K, 120/277V, Triac/ELV

8" Accessories



Emergency Battery Backup

CAT NO.	SPECIFICATIONS
KEM-LD5	8W, 120/277V



Fire Cover

CAT NO.	SPECIFICATIONS
FIRECVR	9 3/4" H x 17" O.D.



Fire Enclosure

CAT NO.	SPECIFICATIONS
FIREENCL	20 3/8" L x 14 3/8" W
FIREENCL-S	Shallow, 16" L x 14 3/8" W



Mica Fire Tape

CAT NO.	SPECIFICATIONS
FIRETAPE	3/4" W x 16' L