

8" Incandescent Architectural Remodel Housing



Features

- 8" Remodel Incandescent Architectural Housing.
- Galvanized Steel construction, commercial frame.
- Single Wall construction.
- Integral Thermal Protector.
- PAR30, PAR38 or A19, Lamp not included.
- Trims feature white polycarbonate ring.
- cUL Listed for damp location.
- Compatible Trims: EL816, EL832, EL833, EL836, EL838, EL852.

Specifications

Wattage	200W
Voltage	120V
Lamp Type	Medium Base (E26)
Damp Location	Listed

Dimensions

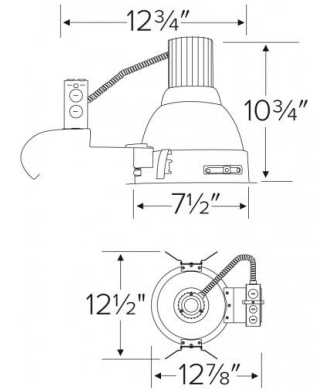

Product Numbers

Item	Lamp type	Watts	Voltage
ELRH8T	Medium Base (E26)	200W	120V