

7" New Construction Incandescent Architectural Housing



Features

- New Construction Incandescent Architectural Housing.
- Galvanized Steel construction, commercial frame.
- Single Wall construction.
- Integral Thermal Protector.
- Lamp and Hanger Bars not included.
- cUL Listed for damp location.
- Compatible Trims: EL716, EL732, EL733, EL738, EL752, EL755.

Specifications

Wattage	150W
Voltage	120V
Lamp Type	Medium Base (E26)
Damp Location	Listed

Dimensions

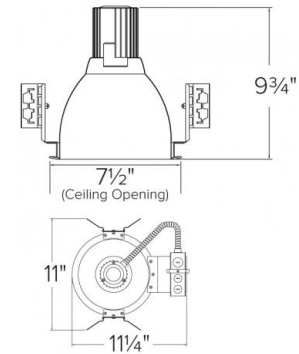

Product Numbers

Item	Lamp type	Watts	Voltage
ELH7T	Medium Base (E26)	150W	120V