

# 4" IC Airtight New Construction Housing for Architectural Koto™ LED Engine

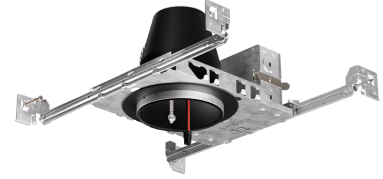

## Features

- IC Airtight for direct contact with insulation.
- Koto™ Architectural Housing: 120/277V 0-10V/Triac/ELV or 120V Triac/ELV with optional Emergency Battery Backup.
- Must be used with Architectural Koto™ LED Light Engines (ELK19, ELK21, or ELK24 Series).
- Lumen output based on module

## Specifications

<b>Wattage</b>	11.8W (12.6W MAX. with ELK19, ELK21 & ELK24)W
<b>Lumens</b>	750 (ELK19) - 950 (ELK21) - 1100 (ELK24) lm
<b>Voltage</b>	120/277V or 120V
<b>Dimmable</b>	Triac/ELV, 0-10V/Triac/ELV (1% Dimming)

## Dimensions

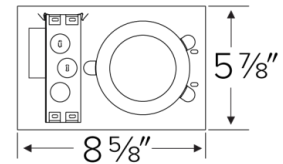
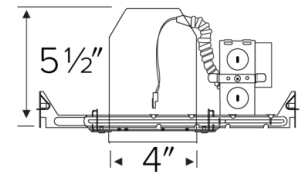

## Technical Details

**Lamp:** Designed for use with ELCO Architectural Koto™ LED Light Engines (ELK19, ELK21, or ELK24 Series)

**Construction:** Single Wall IC Rated for direct contact with insulation, for use in IC or non-IC conditions. Housing adjusts in frame to accommodate up to 1 1/2" ceiling thickness. Airtight housing with gasket to restrict airflow in accordance with ASTM E-283 air-tight requirements.

**Installation:** Designed for ceiling plenums where 2x6 joists or taller joists are used. High strength hanger bars can easily be nailed to joists. Maximum hole cutout is 4 1/4". Suitable for t-grid and drop ceiling applications. See installation sheet for detailed information.

**Junction Box:** Positioned to accommodate straight conduit runs. Seven 1/2" trade size conduit knockouts, four 3/4" knockouts. Pry-out knockout slots. 4 Romex pryouts with strain relief.

**Hanger Bars:** Pre-installed hanger bars with True Nail facilitate easy installation in regular lumber, engineered lumber, and laminated beams. Integral T-bar slots for easy installation in T-bars. Spans up to 24" and can be repositioned 90°. Score lines allow for tool-free hanger bar size reduction. Integral leveling flange allows for single-person installation while aligning the housings with the joists.

**Electrical:** Input Voltage: 120V or 120/277V. High efficiency driver with power factor > 0.9

**Dimmability:** Triac/ELV or Triac/ELV/0-10V (1% dimming)

**Listings:** cUL Listed for Damp Location. cUL Listed for Wet Location with select trims. cUL Listed for Feed Through. cUL Listed for Direct Contact with Insulation. Airtight per ASTM E-283. Install a JA8-2016-E lamp/luminaire for Title 24 Compliance.

**Warranty:** ELCO Lighting warrants products will be free from defects in materials and workmanship for a period of 5 years.

## Product Numbers

Item	Description	Lumens	Watts	Voltage	Dimming
<b>E4LK87ICA</b>	New Construction	750 (ELK19) - 950 (ELK21) - 1100 (ELK24) lm	11.8W (12.6W MAX. with ELK19, ELK21 & ELK24)	120V	Triac/ELV
<b>E4LK88ICAD</b>	New Construction	750 (ELK19) - 950 (ELK21) - 1100 (ELK24) lm	11.8W (12.6W MAX. with ELK19, ELK21 & ELK24)	120/277V	0-10V/Triac/ELV (1% Dimming)
<b>E4LK87ICA-EM1</b>	with 90 min. Emergency Battery Back-Up	750 (ELK19) - 950 (ELK21) - 1100 (ELK24) lm	11.8W (12.6W MAX. with ELK19, ELK21 & ELK24)	120V	Triac/ELV
<b>E4LK88ICAD-EM1</b>	with 90 min. Emergency Battery Back-Up	750 (ELK19) - 950 (ELK21) - 1100 (ELK24) lm	11.8W (12.6W MAX. with ELK19, ELK21 & ELK24)	120/277V	0-10V/Triac/ELV (1% Dimming)

# Product Number Builder

Example: **E4LK87ICA**

4" Koto™ Standard ICA Housing

Voltage

Dimming

**E4LK**

**87** 120V (11.8W) <sup>1</sup>

**88** 120/277V (11.8W) <sup>2</sup>

**ICA** Triac/ELV

**ICAD** 0-10V/Triac/ELV <sup>3</sup>

<sup>1</sup> Available as 120V, Triac/ELV only

<sup>2</sup> Available as 120/277V, 0-10V/Triac/ELV only

<sup>3</sup> 1% Dimming

# Compatible Products

For use with Dedicated 4" Architectural ICA LED Housings



## Koto™ Architectural LED Light Engine

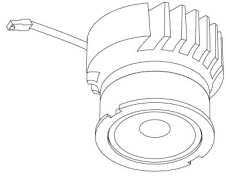

**Koto™ LED Light Engine**  
ELK19 - ELK21

PRODUCT NUMBER BUILDER			
Koto™ LED Light Engine	Lumens	Color Temperature	Beam Angle
ELK			
19	750 - 850 lm*	27D 2700K	(blank) 38° lens (Standard)
21	1100 - 1500 lm*	30D 3000K	-S 18° lens
24	1100 - 1800 lm*	35D 3500K	-N 25° lens
		40D 4000K	-W 60° lens
		SD Sunset Dimming (ELK19 Only)	-FC 18° - 50° Adjustable (ELK21 Only)

\*Wattage based on housing.

### ACCESSORIES



#### Lens

EP731C	18° Lens
EP732C	25° Lens
EP733C	38° Lens
EP734C	60° Lens

\*EP732C, EP733C, EP734C Included



#### Snoot

L50W	White
L50B	Black



#### Secondary Optics

L45	Hex Louver
L46	Linear Lens
L47	Spread Louver
L49	Frosted Lens
L51	Color Shifter

## Koto™ FOCUS Architectural LED Light Engine

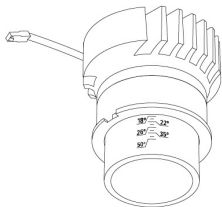

**Koto™ FOCUS LED Light Engine**

PRODUCT NUMBER BUILDER			
Koto™ FOCUS LED Light Engine	Lumens	Color Temperature	Beam Angle
ELK			
21	1100 - 1500 lm	27D 2700K	-FC 18° - 50° Adjustable Focus
		30D 3000K	
		35D 3500K	
		40D 4000K	

\*Wattage based on housing.

## 4" Pex™ Twist-On Trims

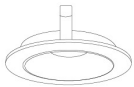

**Shallow Reflector**

ELK4116  
Finishes:  
(W, H)



**Reflector**

ELK4118  
Finishes:  
(W, BB, BZ, B, C, H)



**Adjustable Gimbal**

ELK4129  
Finishes:  
(W, BB, BZ, B, C, H)



**Adjustable Pinhole**

ELK4127  
Finishes:  
(W, B, BB, BZ, N, CP)



**Adjustable Baffle**

ELK4193  
Finishes:  
(W, BB, B)



**Rotatable Slot Aperture**

ELK4120  
Finishes:  
(W)



**Slot Aperture**

ELK4130  
Finishes:  
(W)



**Adjustable Spot**

ELK4188  
Finishes:  
(W, B, BZ)

# Compatible Products



For use with Dedicated 4" Architectural ICA LED Housings & ALO™ Box

## 4" Pex™ Twist-On Trims



**Shallow Reflector**

**ELK4216**

Finishes:

(W, H)



**Reflector**

**ELK4218**

Finishes:

(W, BB, BZ, B, C, H)



**Adjustable Gimbal**

**ELK4229**

Finishes:

(W, BB, BZ, B, C, H)

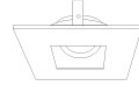

**Adjustable Pinhole**

**ELK4227**

Finishes:

(W, B, BB, BZ, N)



**Adjustable Slot Rotatable**

**ELK4220**

Finishes:

(W)



**Adjustable Phenolic Baffle**

**ELK4293**

Finishes:

(W, BB, B)

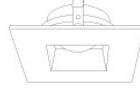

**Adjustable Reflector**

**ELK4282**

Finishes:

(W, BZ)

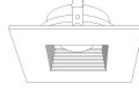

**Adjustable Baffle**

**ELK4284**

Finishes:

(W, B, BZ)

\*Finishes: **W** - All White, **BB** - All Black, **BZ** - All Bronze, **B** - Black Reflector w/White Ring, **C** - Chrome Reflector w/White Ring, **H** - Haze Reflector w/White Ring

## 4" Flexa™ Twist-On Trims



**Round Reflector**

**ELK4721**

Finishes:

(WW, BB, BZBZ, BW, CC, CW, HW, CN)



**Round Baffle**

**ELK4723**

Finishes:

(WW, BB, BZBZ, BW)

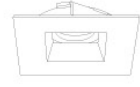

**Square Reflector**

**ELK4741**

Finishes:

(WW, BB, BZBZ, BW, HW)  
\*Not for Remodel Housing

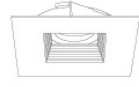

**Square Baffle**

**ELK4743**

Finishes:

(WW, BB, BZBZ, BW)  
\*Not for Remodel Housing



**Adjustable Sq. Reflector**

**ELK4759**

Finishes:

(WW, BB, B, H)

\*Finishes: **W** - All White, **BB** - All Black, **BZ** - All Bronze, **B** - Black Reflector w/White Ring, **C** - Chrome Reflector w/White Ring, **H** - Haze Reflector w/White Ring