

3" New Construction Single Wall Housing

3" single wall housing for new construction applications. For use with MR16 lamps with GU10 base.



Features

- Single wall construction with Thermal Protector
- Lamp: 50W max 120V GU10 MR16
- For use in non-insulated ceilings
- Lamp Holder: Twist-and-lock GU10 MR16 lamp holder
- Trims sold separately

Specifications

Wattage	50W
Voltage	120V
Lamp Type	GU10
Wet Location	Listed with Shower Trims
Damp Location	Listed

Dimensions

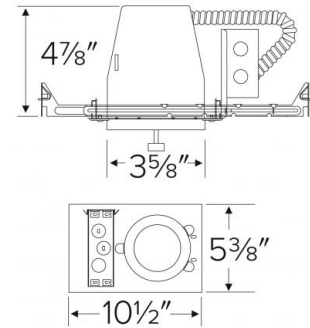

Technical Details

Construction:

- Housing adjusts in frame to accommodate up to 1 1/4" ceiling thickness.
- Steel housing for greater heat dissipation. Stamped galvanized steel frame.

Installation: Designed for ceiling plenums where 2x6 joists or taller joists are used. High strength hanger bars can easily be nailed to joists. Maximum hole cutout is 3 5/8". Suitable for T-grid and drop ceiling applications. See installation sheet for detailed information.

Junction Box: Positioned to accommodate straight conduit runs. Seven 1/2" trade size conduit knockouts, four 3/4" knockouts with pry-out knockout slots. 4 Romex pryouts with strain relief.

Hanger Bars: Pre-installed hanger bars with True Nail facilitate easy installation in regular lumber, engineered lumber, and laminated beams. Integral T-bar slots for easy installation in T-bars. Spans up to 24" and can be repositioned 90°. Score lines allow for tool-free hanger bar size reduction. Integral leveling flange allows for single-person installation while aligning the housings with the joists.

Electrical:

- Input Voltage: 120V AC.
- Thermally protected against improper lamping.

Trims: Compatible with ELCO 3" MR16 trims.

Lamp: Designed for use with GU10 MR16 LED lamps.

Dimmability: Dimmability based on lamp.

Listings:

- UL Listed for Damp Location.
- UL Listed for Wet Location with select trims.
- UL Listed for Feed Through.
- Airtight per ASTM E-283.
- Install a JA8-2016-E lamp/luminaire for Title 24 Compliance.

Warranty: ELCO Lighting warrants products will be free from defects in materials and workmanship for a period of 3 years.

Product Numbers

Item	Lamp type	Watts	Voltage
EL39A	GU10	50W	120V